

SHELTER

Assembly Manual

10m Warehouse Tent

L10.00xW5.00xH4.20m



SPECIFICATION

Length: 10.00m Width: 5.00 m Height: 4.20m

(Please note the measurement is from center to center of the tubes)

IMPORTANT----- READ MANUAL FIRST

Improper site preparation, Assembly and Maintenance may invalidate warranty and cause unnecessary and costly mistakes. If you have any questions contact your local dealer.

For User Friendly assembly we have identify each individual component with the part code as indicated in the parts list. Please refer to the part code numbers and drawing to ensure problem free assembly.

READ ALL INSTRUCTIONS BEFORE ASSEMBLY

1. Keep work area clean. Cluttered areas invite injuries.
2. Be aware of your surroundings. Do not set up near snow drifts, in slippery places, in high winds, or wet location.
3. Keep children away. All children should be kept away from the work area.
4. Don't over reach. Keep proper footing and balance at all times.
5. Do not assemble if under the influence of alcohol or drugs. Read warning labels on prescriptions to determine if your judgment or reflexes are impaired while taking drugs. If there is any doubt, do not assemble.
6. Be aware of possible windy conditions, fasten the bases in concrete if this conditions is likely to occur. Remove the cover during hurricane.
7. Clean off snow before entering. Do not allow snow to sit for extended periods of time.
8. Be careful with power and heat sources. Do not keep heat sources near the tarpaulin. Do not expose to open flame.
9. Be aware of personal safety during assembly and use. Be careful not to pinch fingers with clips and tubes when assembling: when using make sure there is adequate ventilation for exhaust and other dangerous fumes.

Parts List

Part Code	Description	Quantity(PC)
1	Roof Bent Joist	5
2	Sidewall Bent Joist	10
3	Uprights	10
4	Roof & Sidewall Purlin	20
5	Base Plate at four corners	4
6	Base Plate for front & back ends	4
7	Base Plate for Inner sidewall	6
8	Lower Portal for two end	4
9	Upper Portal for two end	4
10	Side Rail at two ends	4
11	Lower Tensioning Tube at two ends	4
12	Angle for two ends	8
13	Bolts M12X100 for purlin connection	25
14	Bolts M10X30 for angle connection	16
15	Bolts M10X90 for joist, portals and sidewall Wire	92
16	Lower Tensioning Tube for roof cover (5pcs per set)	2 sets
17	Tie Down Ratchet (being installed on base plates)	10
18	Roof Cover	1
19	Front & Back Cover	1 each
20	Belts for tie down ratchet	10
21	Kitting Rope for ends of roof cover and end tensioning tube	4
22	Ball Bungee	64
23	Stake Peg	28
24	Earth Auger	10
25	Handle Kit for earth auger	1
26	Tensioning Wire for sidewall	8
27	Plastic Plug for end of tensioning tube	12

FRAME ASSEMBLY

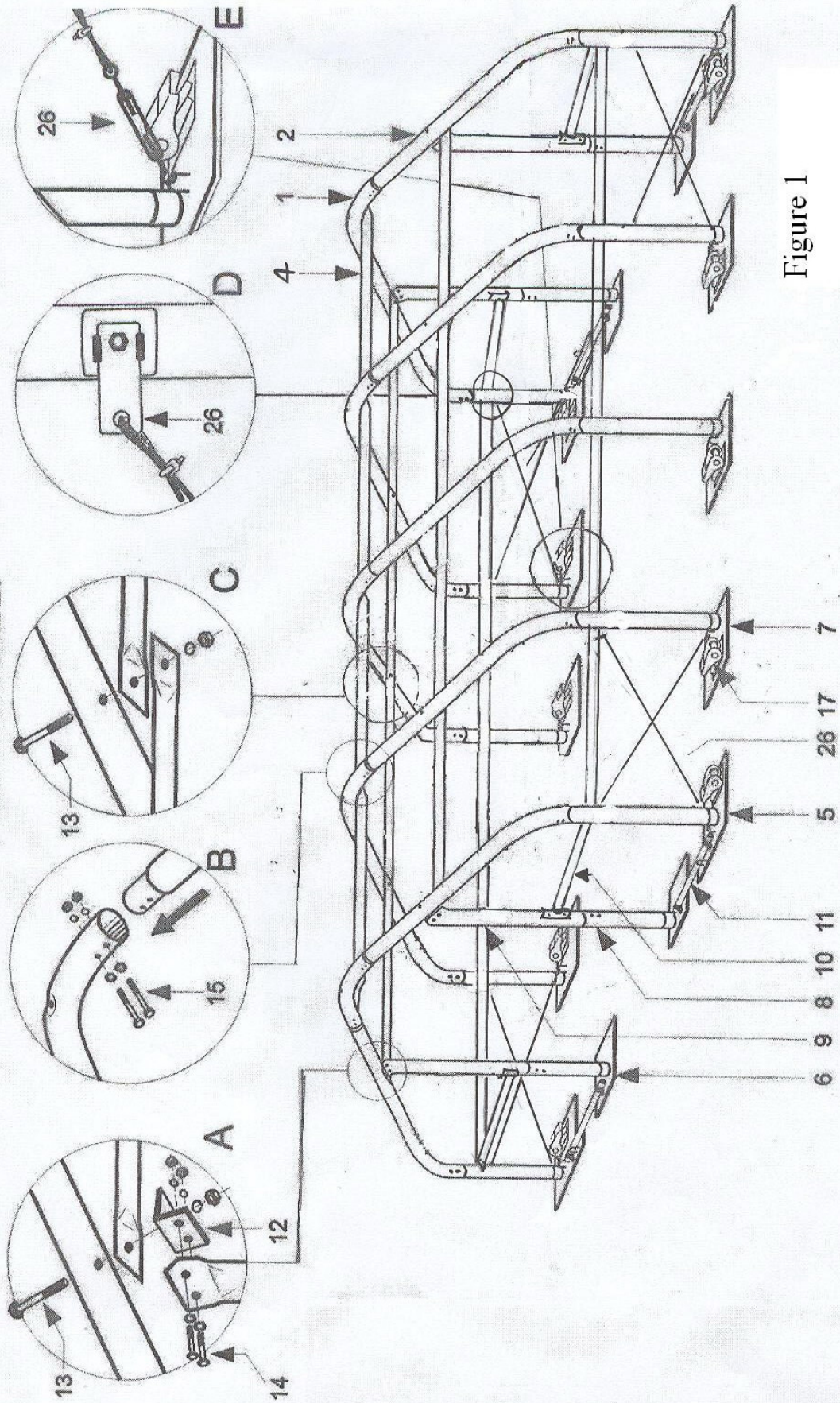

Figure 1

L10.0xW5.0xH4.2m

EQUIPMENT AND MATERIAL FOR INSTALLATION

1. Measuring Tape
2. String for Alignment
3. Stakes
4. Step Ladder
5. Sledge Hammer
6. Drill
7. Wrench

INSTALLATION PROCESS

A—BASE PLATES INSTALLATION

Please refer to the diagram (Figure 2) to place the base plates

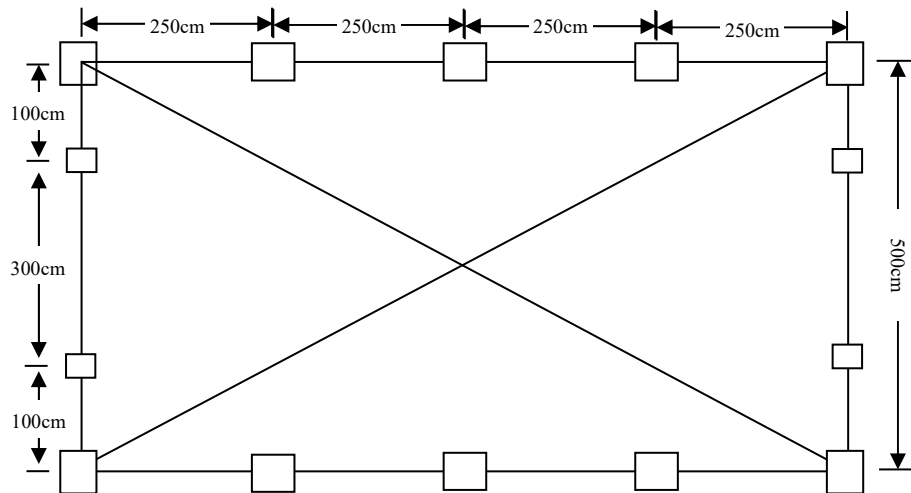

Figure 2

1. The measurement is from center to center of the tubes. Referring to the above diagram and confirm the place of base plates. ENSURE THAT THE FOUNDATION IS SQUARE.
2. There are three holes on the plates, one for earth auger and two for stake peg. Refer to Figure 3 to place the stake pegs and swirl the earth auger into the ground, THUS ALL BASE PLATES ARE SECURED.

Foundation placement

As Figure 3 shows each Base Plate is equipped with one piece of Earth Auger (No.24) and two pieces of Stake Peg (No.23)

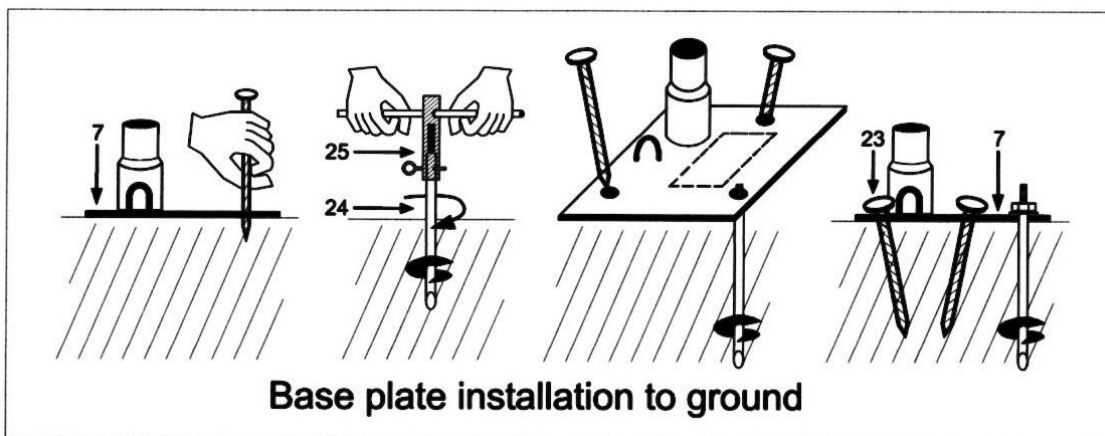

Figure 3

Method of Placing Earth Auger

1. Mark the auger hole through the base plate by using the stake peg. Move the base plates away and the mark determines where the auger will be.
2. Use the Handle Kit (No.25) to turn the auger into ground. Leave sufficient shaft over the ground. Now place the base plates onto the auger through the holes and tighten the washer and nuts through the thread over the shaft over the base plates.

Note: The Earth Auger and Stake Pegs apply for normal conditions, not suitable to the rock ground, frozen soil and concrete ground.

B—FRAME INSTALLATION

1. As Figure 4 shown find Roof Bent Joist (part code1), Sidewall Bent Joist (part code 2) and Upright Tube (part code 3) and assemble every group arch with Screw M10x90(No.15) DO NOT install the screws on the top of the truss where the fabric will rest.
2. Lift an assembled arch onto one base plate and force the other end of the arch onto the opposite base plate.

IMPORTANT: THE ARCHES WILL BE WIDER THAN THE BASE PLATES

3. When finishing install the first two arches into the base pates, use Roof & Sidewall Purlin (part code 4) to connect them by Screw M12x100(No.13). Then install the third arch into the plate and connect the Roof & Sidewall Purlin. In this turn, one arch and then purlin tubes. Then come to install the front panel and back panel. Find the relative components and assemble them.
4. Please refer to Figure 1 for the directions of the angle(No.12), which is used to connect the side rail at two ends(No.10) and Upper Portal (No.9) by screw M10x30 (No.14).
5. Connect the Tensioning Steel Wire (No.26) between the Sidewall tubes, and adjust the length.

Note: Do not fasten the wire now.

You may have to unload it when tightening the roof cover by tie down ratchet.

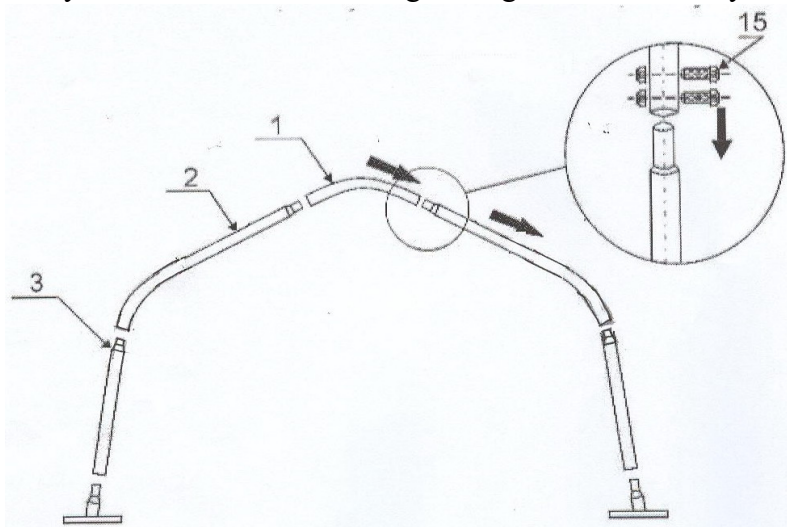

Figure 4

C-INSTALLING THE ROOF COVER

NOTE: DO NOT install the cover onto the frame of your building in high wind conditions. A slight breeze is the most advantageous for cover installation. To take advantage of the breeze, pull the cover up over the arches with the breeze blowing in the cover like a sail filled with air.

1. Assemble lower tensioning tube for roof cover before installing the cover.
2. Roll out the roof cover on a ground sheet. Align the cover evenly to each end of the frame.
Note: Be sure do not overpull the end of the roof cover.
3. Pull the cover over the frame **EVENLY, CAREFULLY AND SLOWLY**. Insert the tensioning tubes into the cover pipe pockets and loosely secure the Belts (part code 20) in the Tie Down Ratchet (part code 17). **DO NOT TIGHTEN**. Adjust the cover so that it is square and evenly centered on the frame. Put the lower tensioning tube inside.

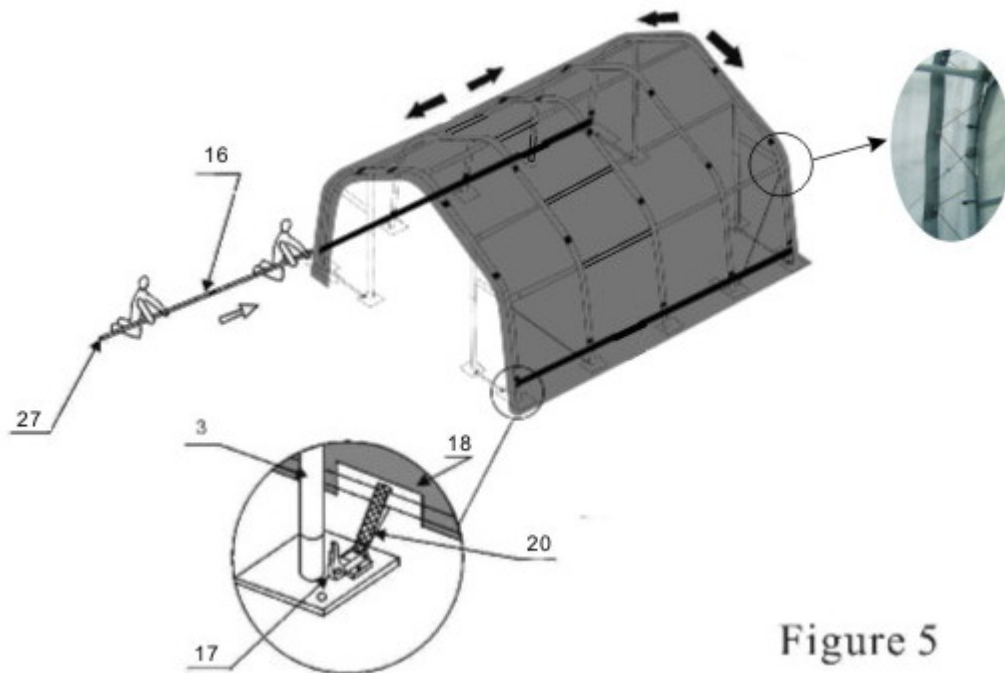

Figure 5

Note: The end flaps must overhang evenly at both ends.

4. With the end flaps flipped back and out of the way, use the supplied rope to tighten the roof cover to the end arches. The rope should be cut as your requirements when using. The recommended procedure is to use separate pieces of rope and start by first lacing the cover from the bottom edges up to the top center. Secure the ropes at the top center and then apply tension as you lace down both sides. Fasten the rope at the bottom edge. Put the Belts (part code 20) onto the tubes where the notches are. Pull the Belts through the reels of Tie Down Ratchet (part code 17). Drive the Ratchet Tie Down forth and back and then roof cover is tightened.

D-INSTALLING THE FRONT AND BACK COVER

Fit the Tensioning tube into the Saddle Brackets as shown.

Use rope to lace the grommets in the end to the tensioning tubes tightly and evenly.

The end covers are tied to the frame (uprights, roof joists) by tie down ratchet.

They are also been secured to the end frame (door tube and side rail) by rope for lacing.

Method of Fastening Front and Back Cover

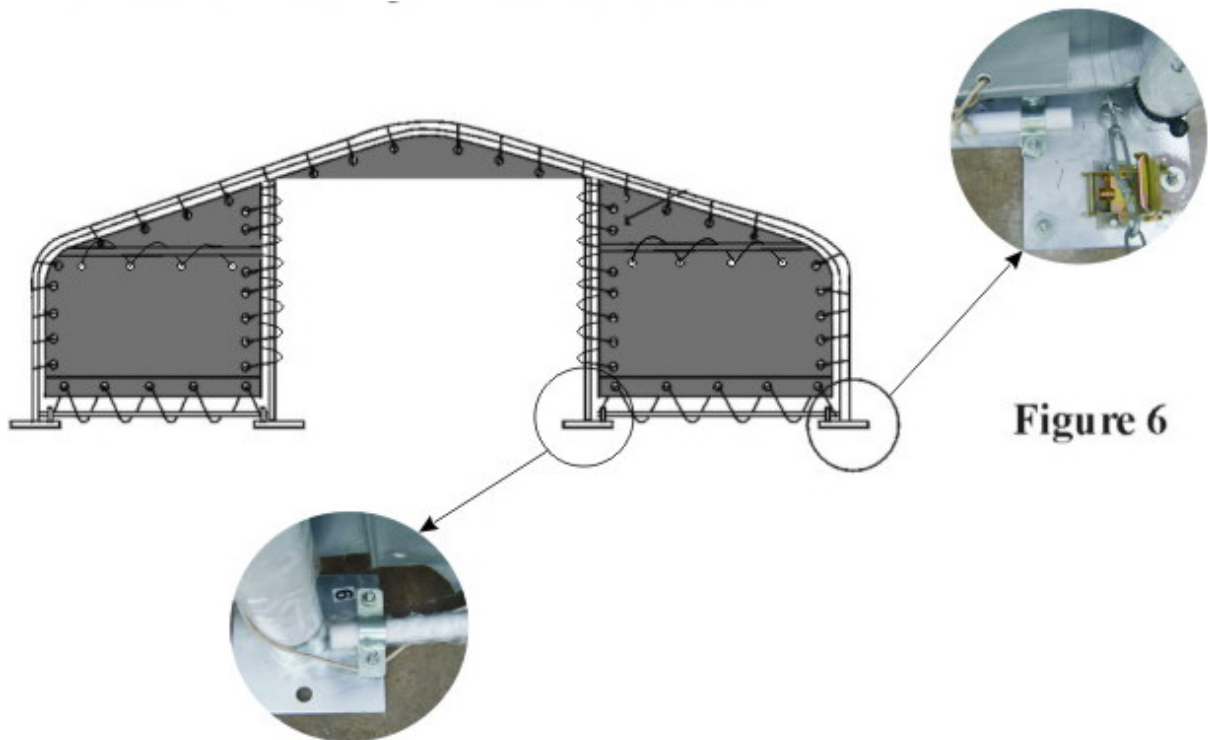

Tidy the cover, Roof Cover, Back Cover and Front Cover. Fasten the band inside the end the roof cover, make the cover well fold to the frame and tie the end of the band to the Clips on Base Plates at four corners.

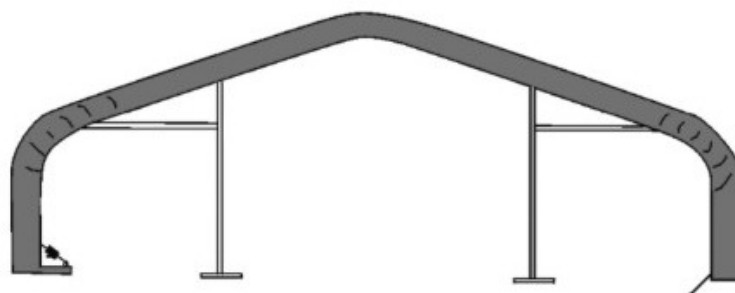

Figure 7

Now your assembly is completed.

Effective Photos for your reference



1



2

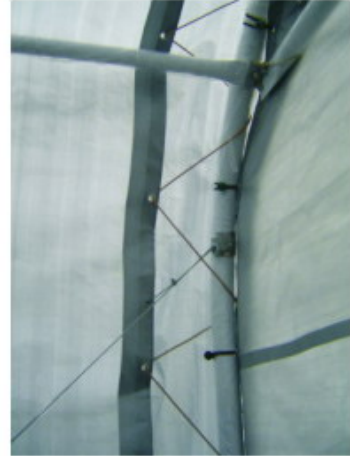

3



4

1---tensioning wire for sidewall

2---two end covers rope lacing

3---roof cover end rope lacing

4---outlook of the completed tent